

CCTV Camera
WV-BP70

Operating Instructions



Panasonic®

Before attempting to connect or operate this product,
please read these instructions completely.

**CAUTION**RISK OF ELECTRIC SHOCK
DO NOT OPEN

CAUTION:
TO REDUCE THE RISK OF ELECTRIC SHOCK, DO NOT REMOVE COVER (OR BACK). NO USER SERVICEABLE PARTS INSIDE.
REFER SERVICING TO QUALIFIED SERVICE PERSONNEL.



SA 1965

The lightning flash with arrowhead symbol, within an equilateral triangle, is intended to alert the user to the presence of uninsulated "dangerous voltage" within the product's enclosure that may be of sufficient magnitude to constitute a risk of electric shock to persons.



SA 1966

The exclamation point within an equilateral triangle is intended to alert the user to the presence of important operating and maintenance (servicing) instructions in the literature accompanying the appliance.

WARNING:

TO PREVENT FIRE OR SHOCK HAZARD, DO NOT EXPOSE THIS APPLIANCE TO RAIN OR MOISTURE.

For U.S.A.

Warning:

This equipment generates and uses radio frequency energy and if not installed and used properly, i.e., in strict accordance with the instruction manual, may cause harmful interference to radio communications. It has been tested and found to comply with the limits for a Class A computing device pursuant to Subpart J of Part 15 of FCC Rules, which are designed to provide reasonable protection against such interference when operated in a commercial environment.

For CANADA

This digital apparatus does not exceed the Class A limits for radio noise emissions from digital apparatus set out in the Radio Interference Regulations of the Canadian Department of Communications.

The serial number of this product may be found on the bottom of the unit.

You should note the serial number of this unit in the space provided and retain this book as a permanent record of your purchase to aid identification in the event of theft.

Model No. WV-BP70

Serial No. _____

CONTENTS

PREFACE	2
FEATURES	2
PRECAUTIONS	3
MAJOR OPERATING CONTROLS AND THEIR FUNCTIONS	4
CONNECTIONS	6
LENSES	7
FOCUS OR FLANGE-BACK ADJUSTMENT	8
INSTALLATION OF CAMERA	9
INSTALLING PROCEDURE	10
PREVENTION OF BLOOMING AND SMEAR	12
LENS MAINTENANCE AND CLEANING	12
SPECIFICATIONS	13
STANDARD CONFIGURATION	14
OPTIONAL ACCESSORIES	14

PREFACE

Panasonic's WV-BP70 CCTV Camera introduce a new level of high picture quality through the use of a 1/3 inch interline transfer CCD having 512 horizontal pixels (picture elements). High performance-to cost ratio is achieved through the use of newly developed fixed iris lens by use of Electronic Light Control (ELC) function.

FEATURES

- Minimum illumination of 0.01 footcandle (0.1 lux) at F1.2, 0.015 footcandle lux (0.15) at F1.4 or 0.2 footcandle (2 lux) at F2.8 (provided lens) and Signal-to noise ratio of 46 dB by employing a 1/3 inch interline transfer CCD image sensor with 512(H) x 492(V) pixels.
- 380 lines of horizontal resolution.
- Ability to shoot indoor scenes with fixed iris lens by use of Electronic Light Control (ELC) function.

PRECAUTIONS

- **Do not attempt to disassemble the camera.**

To prevent electric shock, do not remove screws or cover. There are no user-serviceable parts inside.

Refer servicing to qualified service personnel.

- **Handle the camera with care.**

Do not abuse the camera. Avoid striking or shaking it. The camera could be damaged by improper handling or storage.

- **Do not expose the camera to rain or moisture, or try to operate it in wet areas.**

Do take immediate action if ever the camera do becomes wet. Turn power off and refer servicing to qualified service personnel. Moisture can damage the camera and also create the danger of electric shock.

- **Never face the camera toward the sun.**

Whether the camera is in use or not, never face it toward the sun. Do use caution when operating the camera in the vicinity of spot lights or other bright lights and light reflecting objects.

- **Do not operate the camera beyond its temperature or humidity**

Do not use the camera in an extreme environment where high temperature or high humidity exist. Use the camera under conditions where temperatures are within -22°F - 122°F (-30°C - $+50^{\circ}\text{C}$), and humidity is below 90%.

MAJOR OPERATING CONTROLS AND THEIR FUNCTIONS

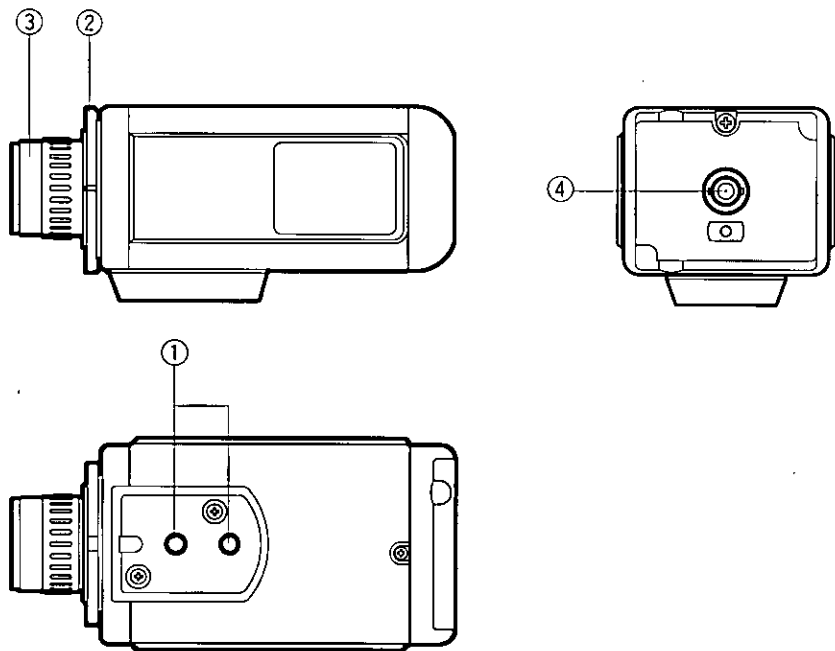

(1) Camera Mounting Screw Hole

This threaded hole (1/4" - 20) is used to mount the camera onto a mounting bracket or tripod.

(2) Flange-back Adjusting Ring

This ring is used to adjust the back focal length or picture focus by rotating this ring to counterclockwise.

Caution:

Always set this ring to fully clockwise before mounting the lens.

(3) Lens

This is the fixed iris lens.

When using the optional lens, use the Manual or Fixed Iris type lens listed on page 7.

(4) Video Output Connector

This connector is used to connect a coaxial cable to the CAMERA INPUT of specified monitor or camera drive unit, and accept DC power and vertical drive pulse, and supplies video output of the camera.

ELC (Electronic Light Control)

In this mode a continuously variable electronic shutter is employed to automatically control exposure times in the CCD Image Sensor, according to the incoming light level.

Caution:

Under certain unique lighting conditions, the following may appear;

- Strong smear and/or blooming on high light objects such as spot lights or windows.
- Noticeable flicker on the picture.

CONNECTIONS

Cautions:

1. Keep the Power Switch of the monitor, optional Camera Extension Unit and optional Remote Control Unit in the OFF position during connection. If the power of these units are ON during connection, the camera will not function due to the protection circuit for misconnection.
2. Connect only the specified monitor WV-BM80/WV-BM90A or Camera Drive Unit WV-PS11A, WV-PS104B or Camera Extension Unit WV-83.

■ BASIC SYSTEM

Connect the single coaxial cables between the cameras and monitor WV-BM80 (CAMERA INPUT). The approx. maximum cable length is as;

Coaxial Cable Type	Maximum Cable Length	DC Maximum Loop Resistance
RG-59/U	330 ft 100 m	Less than 30 ohms
RG-6/U	825 ft 250 m	Less than 12 ohms

The maximum DC resistance between the camera and monitor is 10 ohms.

■ Connection Diagram

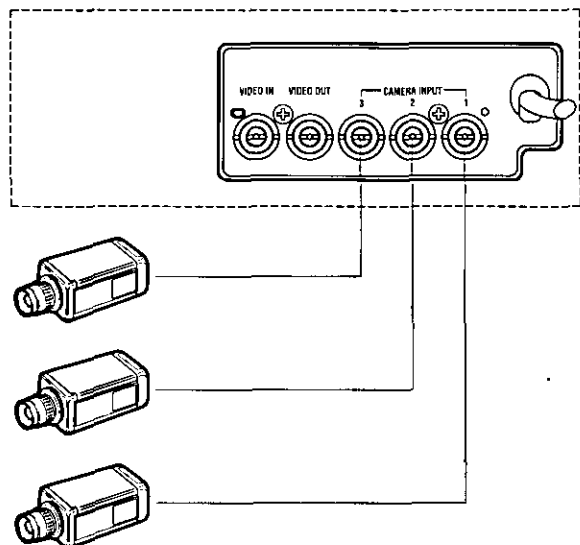

LENSES

1. Selection of Lens

<Manual and Fixed Iris Lenses>

Models Specifications	WV-LM4R5A (Wide Angle)	WV-LM6B2 (Wide Angle)	WV-LM12B2 (Standard)	WV-LF4R5C3A (Wide Angle)	WV-LF9C3A (Wide Angle)	
Image Size	1/2" (6.4 (H) x 4.8 (V) mm)			1/3" (4.8 (H) x 3.6 (V) mm)		
Focal Length	4.5 mm	6 mm	12 mm	4.5 mm	9 mm	
Maximum Aperture Ratio	1 : 1.4	1 : 1.4	1 : 1.4	1 : 1.2	1 : 1.2	
Angular Field of View	H	72.6° [56.9°]	56.8° [43.5°]	30.4° [22.8°]	56.4°	29.6°
	V	56.7° [43.6°]	43.5° [33.0°]	22.8° [17.1°]	43.3°	22.2°
Iris	Manual	Manual	Manual	Fixed	Fixed	
Focusing Range	Adjusted by Camera					
Mount	CS-mount, 1"-32UN					
Filter Size	ø37.5 mm, P = 0.5	None	None	ø30.5 mm, P = 0.5	ø30.5 mm, P = 0.5	
Dimensions	ø1-3/4" x 1-5/8" (ø44 x 41 mm)	ø1-11/16" x 1-9/16" (ø43 x 39 mm)	ø1-11/16" x 1-9/16" (ø43 x 39 mm)	ø1-3/8" x 1-7/16" (ø34.4 x 36 mm)	ø1-3/8" x 1-7/16" (ø34.4 x 36 mm)	
Weights	0.20 lbs. (93g)	0.10 lbs. (45g)	0.08 lbs. (35g)	0.06 lbs. (29g)	0.05 lbs. (23g)	

- [] indicates an angle used with the camera WV-BP70.
- Dimensions and weights indicated are approximate.
- Specifications are subject to change without notice.

2. Mounting the lens

When you use the lens other than listed on page 7, lens mount should be CS mount and lens weight should be less than 0.99 lbs (450g).

If not, both the lens and camera should be secured.

The protrusion of the rear of the lens should be as shown below.

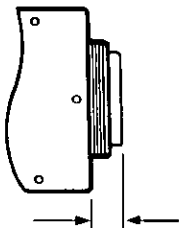

CS-mount : Less than 1/4" (7.2 mm)

FOCUS OR FLANGE-BACK ADJUSTMENT

The following adjustment should be made by qualified service personnel or system installers.

1. Loosen screws on the flange-back adjusting ring.

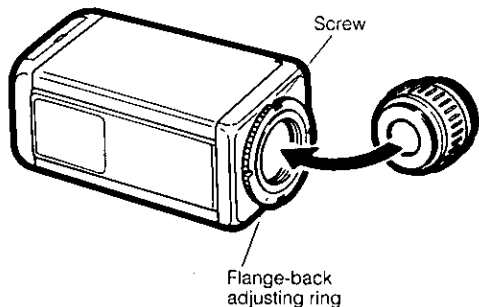

2. Turn the flange-back adjusting ring to the desired position.

Caution:

Do not turn this ring too much to counterclockwise as this could damage the inner glass and CCD image sensor.

3. Tighten the screws on the flange-back adjusting ring.

INSTALLATION OF CAMERA

- **Mounting from the top**

Remove the mount adaptor from the bottom of the camera as shown. The hole is the standard photographic pan-head screw size (1/4" - 20).

Make sure that two original screws are used when mounting the mount adaptor, longer type screws may damage inner components.

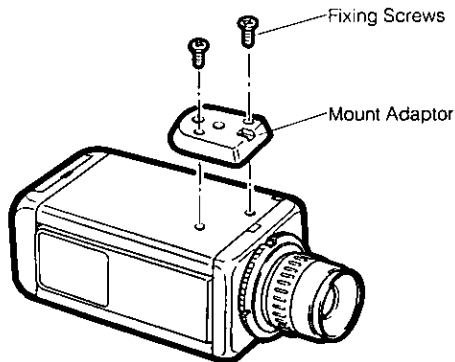

The mounting bracket can be fixed either on top or the bottom cover of the camera.

• Installation on the wall

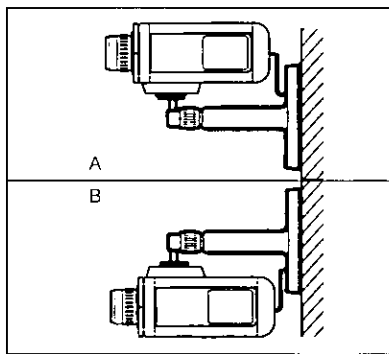

Fig. A, B

• Installation on the ceiling

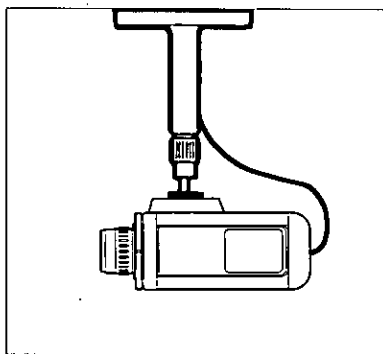

Fig. C

• Installation on the shelf or stand

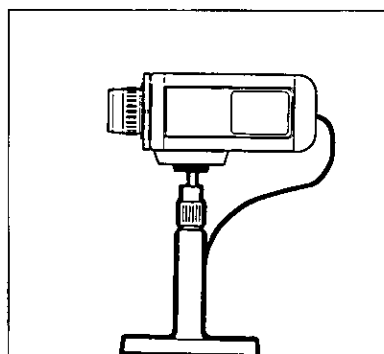

Fig. D

INSTALLING PROCEDURE

The explanation is for the Fig. A, however the same is applied for the Figs. B, C and D.

1. Install the camera mounting bracket to the wall with 2 screws.

Note:

Coaxial cable can be passed through the centre hole of the camera mounting bracket.

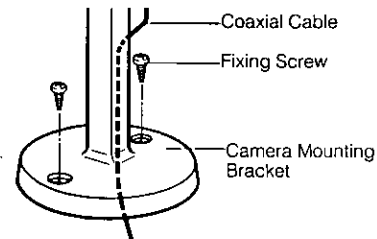

2. Insert the camera fixing screw of the camera mounting bracket into the camera mounting hole and tighten the screw firmly.

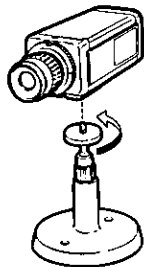

3. Connect the camera and monitor with the coaxial cable and turn on the power switch of the monitor.
4. While viewing the monitor picture, loosen the angular control screw slightly. Adjust the camera's angle to the desired position, and then tighten the screw firmly.

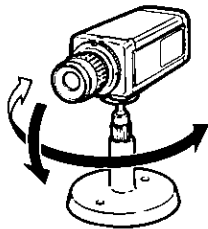

Angular Control Screw

DIMENSION OF MOUNTING BRACKET

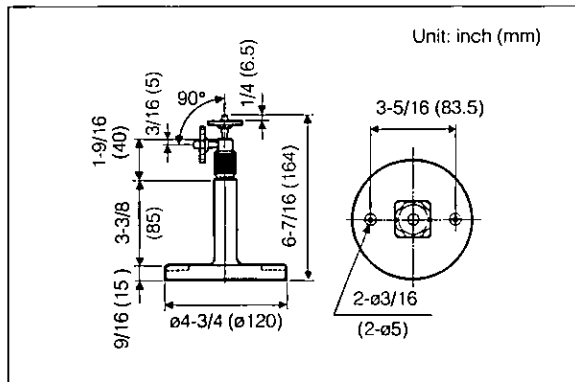

Cautions on installation

Use wood screws with the camera mounting bracket that are suitable for installation into a wood base of appropriate dimensions and strength. For the installation into a material other than wood, refer servicing to qualified service personnel.

PREVENTION OF BLOOMING AND SMEAR

When the camera is faced toward spot lights or other bright lights and light reflecting objects, smear or blooming may appear. Therefore, the camera should be operated carefully in the vicinity of extremely bright objects to avoid smear or blooming.

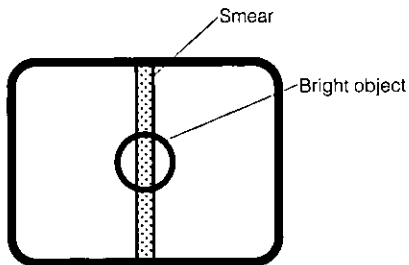

LENS MAINTENANCE AND CLEANING

1. Remove the lens, and inspect the camera CCD faceplate through the lens mount opening to assure that the faceplate is free of smudges or particles of dirt.
2. Clean the CCD faceplate, if necessary, using lens tissue or a cotton tipped applicator and ethanol.
3. Install the new lens.

SPECIFICATIONS

Pick-up Device :	512 (H) x 492 (V) pixels, Interline Transfer CCD
Scanning Area :	4.8 (H) x 3.6 (V) mm (Equivalent to scanning area of 1/3" pick-up tube)
Scanning System :	2 : 1 interlace
Scanning :	525 lines / 60 fields / 30 frames
Horizontal :	15.734 kHz
Vertical :	59.94 Hz
Horizontal Resolution :	380 lines
Video Output :	1.0 Vp-p composite 75 ohms / BNC connector
Signal-to-Noise Ratio :	46 dB
Electronic Light Control :	Equivalent to continuous variable shutter speed between 1/60 sec. and 1/80,000 sec.
Minimum Illumination :	0.01 footcandle (0.1 lux) at F1.2 AGC ON, 0.015 footcandle (0.15 lux) at F1.4 AGC ON, 0.2 footcandle (2 lux) at F2.8 AGC ON (provided lens)
Lens :	F 2.8, f = 4.5 mm
Angular Field of View :	62.5° (H) x 46.5° (V)
Ambient Operating Temperature :	-22°F - 122°F (-30°C - +50°C)
Ambient Operating Humidity :	Less than 90%
Dimensions (with lens) :	2-13/16" (W) x 2-9/8" (H) x 5-7/8" [71 (W) x 65 (H) x 149 (D) mm]
Weights (with lens) :	1.0 lbs (0.45 kg)

Weights and dimensions indicated are approximate.
Specifications are subject to change without notice.

STANDARD CONFIGURATION

Lens1 pc.
Camera Mounting Bracket1 pc.

OPTIONAL ACCESSORIES

Lenses : WV-LM4R5A, WV-LM6B2, WV-LM12B2
WV-LF4R5C3A, WV-LF9C3A

Panasonic

Broadcast & Television Systems Company

Division of Matsushita Electric Corporation of America

CLOSED CIRCUIT VIDEO EQUIPMENT DIVISION

Executive Office: One Panasonic Way, Secaucus, New Jersey 07094

Regional Offices:

Northeast: 43 Hartz Way, Secaucus, NJ 07094 (201) 348-7303

Southeast: 1854 Shackleford Court, Suite 115, Norcross, CA 30003 (404) 717-6835

Midwest: 1707 North Randall Road, Elgin, IL 60123 (708) 468-5200

Southwest: 4500 Amon Carter Blvd., Ft. Worth, TX 76155 (817) 685-1117

Western: 6550 Katella Ave., Cypress, CA 90630 (714) 373-7265

MATSUSHITA ELECTRIC OF CANADA LIMITED

5770 Ambler Drive, Mississauga, Ontario, L4W 2T3 Canada (905)624-5010

PANASONIC SALES COMPANY

DIVISION OF MATSUSHITA ELECTRIC OF PUERTO RICO, INC.

San Gabriel Industrial Park, 65th Infantry, Ave. KM. 9.5 Carolina, Puerto Rico 00630 (809)750-4300

N0294-0

YWV8QA3277AN

Printed in Japan

Ⓝ 13